

P.C.B LAYOUT MOUNTING PATTERN

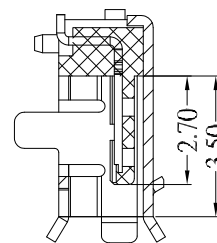
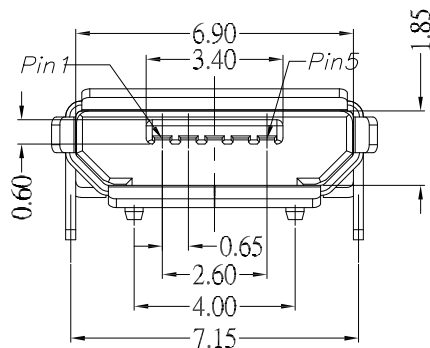
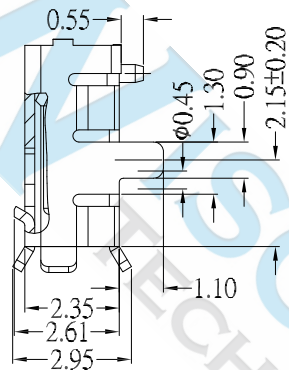
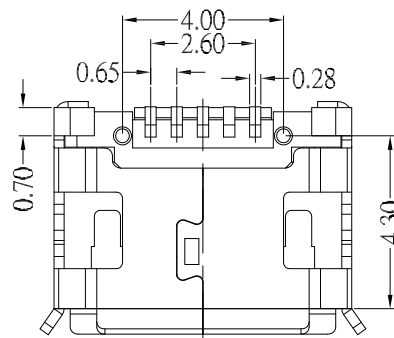

SECTION A-A'

NOTES:

MATERIAL:

- 1.1 HOUSING: LCP UL94V-0 ,Black
- 1.2 CONTACT: PHOSPHOR BRONZE
- 1.3 SHELL: BRASS

Finish:

- 2.1 Contact: Plated Gold in Mating Area ;
Gold Plated on Solder Balls
Nickel under plated overall

3.SPECIFICATION:

- 3.1 CURRENT RATING: 1.0 A MAX
- 3.2 DIELECTRIC WITHSTANDING VOLTAGE:
100 V(ac) FOR 1min
- 3.3 CONTACT RESISTANCE: 30 mΩ MAX.
- 3.4 INSULATION RESISTANCE: 100 MΩ MIN.
- 3.5 TOTAL MATING FORCE: 3.57 Kgf MAX.
- 3.6 TOTAL UNMATING FORCE: 1.0 Kgf MIN.
- 3.7 LIFE: 10,000 CYCLES
- 3.8 TEMPERATURE RANGE: -30°C ~ +80°C

DIMENSIONS TOLERANCE

METRIC

Up to 5	±0.2
Above 05~15	±0.3
Above 15~30	±0.4
Above 30~50	±0.5
Angle	±0.3°

UNITS	MM	FINISH	SEE NOTE	CH'K	Calvin
QT'Y	N/A	DRAW	Johnson	APP'D	Selena
MT'L	SEE NOTE	DE'N	Mike	DATE	September . 19 . 2023

DRAW NAME

MICRO USB B TYPE (Shell DIP Pitch 7.15)

PART NUMBER

WMRU2-05FLBDSR-4.0

DRAW NUMBER

T002

FILE NAME .DWG

WISCONN Technology Co., Ltd

Tel:+886-2-2790-1979 Fax:+886-2-2790-1569

SCALE	1/1	SIZE	A4	SHEET	1	REV.	A
-------	-----	------	----	-------	---	------	---